

# Pacific Scientific Model 6410

## 24-75 Volt, 5A rms Microstepping Stepper Drive

### FEATURES

- Single power supply
- Patented 4-phase Bipolar Chopper Drive for superior current regulation and low ripple current
- Output current adjustable from 0.625 A to 5 A rms with 3 position dipswitch
- Microstepping for smooth operation and increased resolution.
- Patented digital electronic damping reduces instability at speeds in middle of operating range.
- Idle current reduction to reduce motor heating in many applications
- Fault protection:
  - Line-to-line and line-to-neutral shorts
  - Internal power supply under-voltage
  - Bus overvoltage
- Optically isolated command interface:
  - Step
  - Direction
  - Enable
  - Enabled output
- Selectable step filter
  - Rejection of electrical noise on step input
- Small size - Only 7.5 in<sup>2</sup> of panel space (5" x 1.5" x 4.3")
- UL recognized

### APPLICATIONS

- X-Y tables and slides
- Packaging machinery
- Robotics
- Specialty machinery
- Index feed of materials
- Labeling machines

### PRODUCT DESCRIPTION

The Pacific Scientific 6410 is a low cost, compact stepper drive converting step and direction inputs into winding currents for two-phase stepper motors.

Resolution with 1.8° motors is adjustable to 200, 400, 1000, 2000, 5000, 10,000, 25,000, or 50,000 steps per revolution with decimal step size selected, and 400, 800, 1600, 3200, 6400, 12800, 25600, or 51200 steps per revolution with binary step size selected. Higher resolution (microstepping) provides smoother operation through resonance regions as well as increased position resolution.

The 6410 operates from a single supply voltage ranging from 24 Vdc to 75 Vdc.

The default output current is 5A rms. The current can be reduced in increments of 0.625 A using a 3 position DIP switch.

A patented 4-phase PWM (pulse width modulated) chopper electronically controls the motor winding currents at 20 KHz. This combines the best of recirculating and non-recirculating current regulation to provide high back EMF rejection with low ripple current. Benefits include reduced heat dissipation, low electrical noise and improved current control during dynamic braking.

The patented digital electronic damping eliminates motor oscillations common with stepper systems at speeds in the middle of the operating region.

This, along with 4-phase chopping gives significantly more motor output power than competitive systems.

Idle current reduction can be used to reduce motor current by 50% if no step commands have been received for 0.1 second (0.05 and 1.0 seconds can also be selected). Current is restored to full amplitude upon arrival of a step command.

The 6410 uses just 7.5 in<sup>2</sup> of panel space. The optional side mounted heat sink increases width by 1.0" to 2.5". Heat can be removed either from the rear or side of the driver (cold plate mounting) allowing maximum flexibility for system packaging.



**Pacific Scientific 6410**

### SPECIFICATIONS

#### Input Power:

**Voltage** 24 Vdc to 75 Vdc  
**Current** Motor and load dependent.  
 Usually < motor phase current.

#### Output motor phase current

5 A rms max.  
 5 A peak full step  
 7.1 A peak microstepping  
 Adjustable from 0.625 to 5 A rms in 0.625 amp increments (See Figure 3)

#### Inputs STEP

(See Figures 1 and 2)  
 Optically isolated TTL compatible  
 Minimum opto current (opto on): 5.5 ma  
 Maximum opto current (opto on): 10 ma  
 Minimum pulse width: 250 ns (1 μs)  
 Maximum frequency: 2 MHz (**500 KHz**)  
 Motion occurs on low-to-high transition of STEP- input  
**Note: BOLD** values indicate step filter enabled

#### DIR

Optically isolated TTL compatible  
 For normal motor connections:  
 Current in opto (opto on): Rotation  
 CCW looking at motor shaft  
 Minimum opto current (opto on): 3 ma  
 Maximum opto current (opto on): 4.5 ma  
 Minimum setup time: 50.0 μs  
 Minimum hold time: zero

#### ENABLE

Optically isolated TTL compatible  
 Sense of ENABLE input can be changed using ENBL\_SENSE jumper:  
 Jumper In: Current in opto (opto on) enables driver  
 Jumper Out: Current in opto (opto on) disables driver  
 Minimum opto current (opto on): 3 ma  
 Maximum opto current (opto on): 4.5 ma

# SPECIFICATIONS (continued)

**Output** (See Figures 1 and 2)  
**ENABLED** Optically isolated open collector, open emitter  
 Drive Enabled: opto transistor on,  
 $V_{sat} = 0.5 \text{ V max. @ } 2.0 \text{ ma}$   
 Drive Disabled: opto transistor off,  
 $V_{ce \text{ max.}} = 35 \text{ V}$

**Step Size** Set using 3 positions of DIP switch and decimal jumper (See Figure 3).

<u>Step Size</u>	<u>Steps per Revolution</u> (1.8° motor)
Full (1/2)	200 ( <b>400</b> )
1/2 (1/4)	400 ( <b>800</b> )
1/5 (1/8)	1000 ( <b>1600</b> )
1/10 (1/16)	2000 ( <b>3200</b> )
1/25 (1/32)	5000 ( <b>6400</b> )
1/50 (1/64)	10000 ( <b>12800</b> )
1/125 (1/128)	25000 ( <b>25600</b> )
1/250 (1/256)	50000 ( <b>51200</b> )

**Note:** Binary values are in **BOLD**

**Idle Current Reduction** Enabled or disabled with DIP switch  
 50% output current reduction after 0.1 second from last step command  
 (0.05 and 1.0 second time-outs can also be selected using a plug-on jumper. Consult factory for other current reduction options)  
 See Figure 3.

**Mid-band instability compensation** Enabled or disabled with DIP switch (See Figure 3)  
 Max. delay from input step to change in motor excitation:  
 Step frequency < 500 full steps/sec: 500  $\mu\text{s}$   
 Step frequency > 500 full steps/sec: 270° of step period

**Protection** (Any fault disables the drive and must be cleared by cycling input power)  
 Line to Line Short

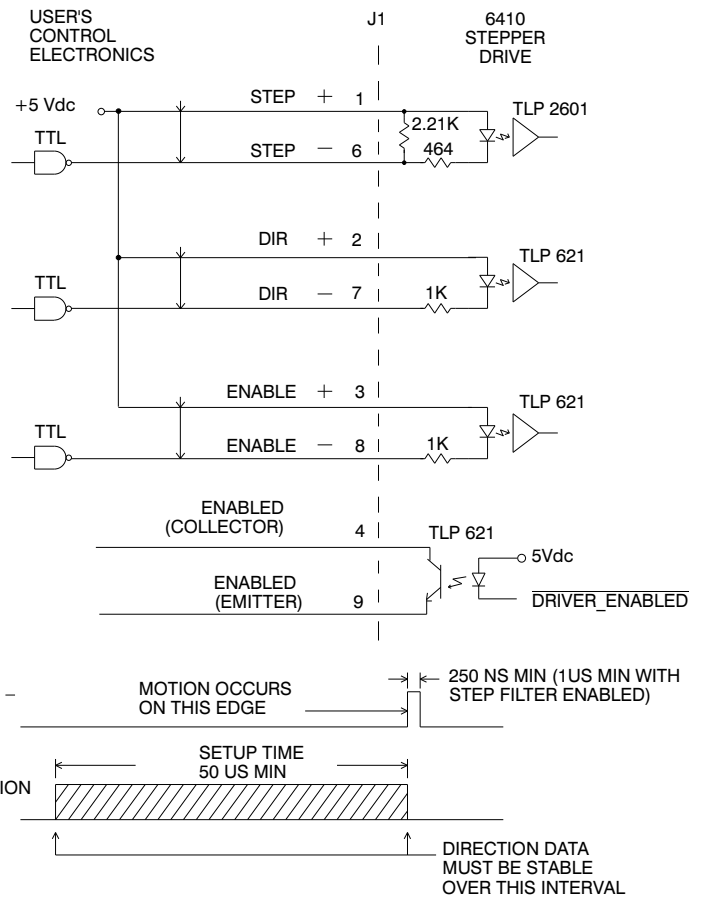

**Figure 2 - Interface Circuits**

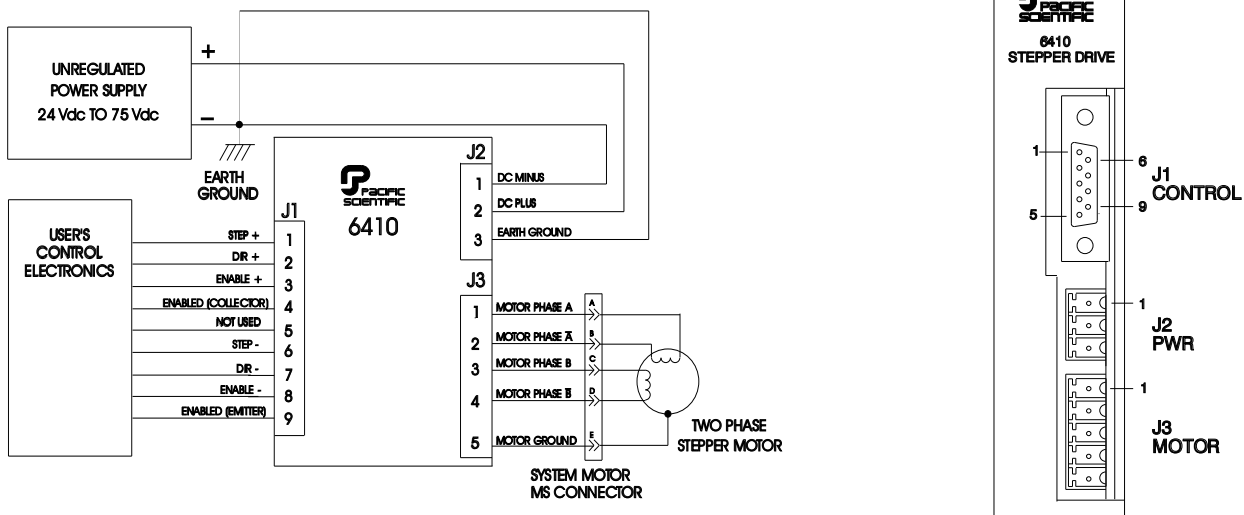

**Figure 1 - 6410 Connection Diagram**

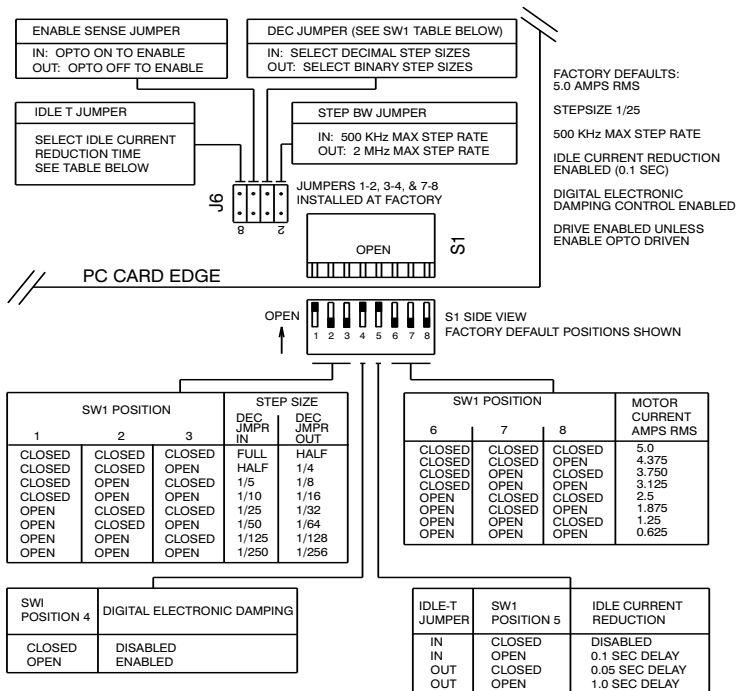

Figure 3 - Dip Switch Settings

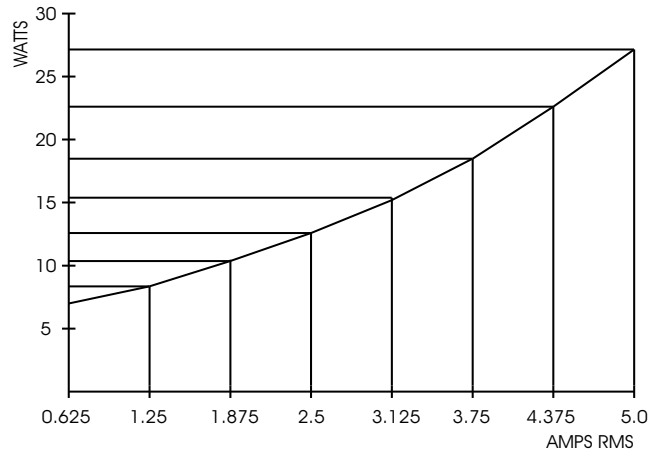

Figure 4 - Power Dissipation vs. Output Current

**Environmental Requirements**

- Storage temperature** -55°C to +70°C
- Operating temperature** 0 to 50°C ambient air with or without cover
- Maximum Chassis Temperature** 60°C  
*Note: For optimal thermal performance, mount the 6410 chassis (back or side) to a cooling plate or heatsink. Use a thermal pad or grease if surface is irregular. A fan or idle current reduction may be employed to keep chassis below 60°C.*
- Convection Cooling** (6410 not mounted on cooling plate)
  - w/optional heat sink** Full rating (5A) at 25°C Ambient  
2.5A max at 45°C Ambient
  - without heat sink** 2.5A max at 25°C Ambient  
1.25A max at 45°C Ambient
 See Figure 4 for plot of drive power dissipation vs. output current.
- Humidity Range** 10 to 90%, non-condensing

**Mechanical**

- Dimensions** 5" x 1.5" x 4.3" (without cover)  
5" x 1.7" x 4.3" (with cover & screws)
- Weight** 1 lb. nominal

**Connectors**

- (see Figure 1)
- Power Supply** 3 contact plug-in screw terminal
- Motor** 5 contact plug-in screw terminal
- Signal** 9 Socket D Sub miniature

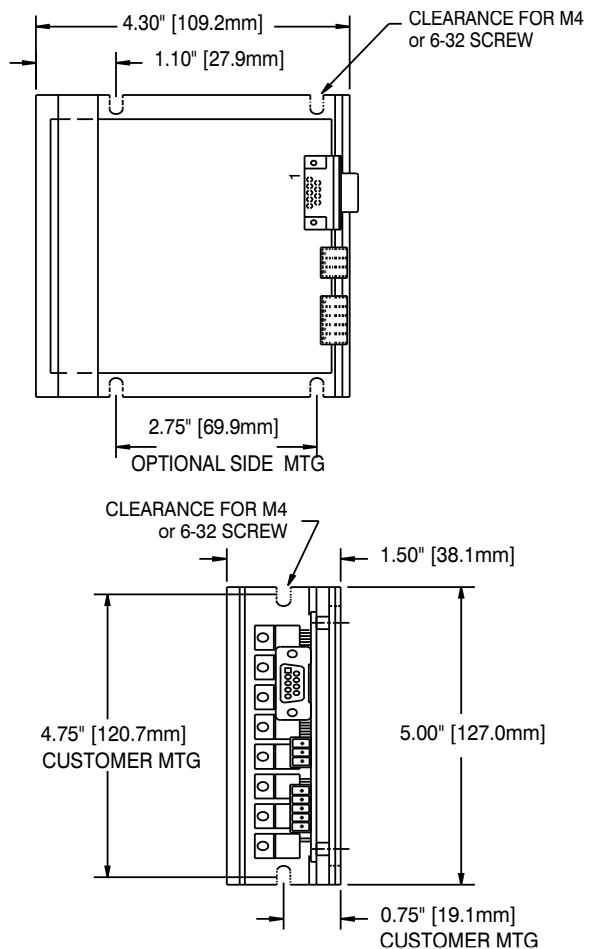

Figure 5 - Mounting Dimensions