

FEATURES

- Economical Position/Speed Control
- Accel and Decel Control
- Two selectable run speeds
- Separate (latched) Run/Stop Inputs for clutch brake applications
- Internal and/or External Command
- Off line 120/240 Vac 60/50 Hz
- Patented 4-phase Bipolar Chopper Drive for superior current regulation and low ripple current
- Output current adjustable from 0.625 A to 5 A rms with 3 position DIP switch
- Microstepping for smooth operation and increased resolution
- Wide Speed Range
- Stable over operating temperature range ($\pm 1\%$)
- Switch selectable Step Size and Current
- Patented Digital Electronic Damping reduces instability at mid-speed ranges
- Adjustable Idle Current Reduction
- External Pulse Output
- Drive Fault protection:
 - Line-to-line and line-to-neutral shorts
- Power supply fault protection:
 - Over temperature
 - Short circuit
 - Under voltage
- Output for 2nd Axis
 - 66 Vdc \pm 2 volts available via three position plug-in connector (J6) to power additional axis (total power available for internal and external axis = 300 W)
- Small size - 6.25" x 2.25" x 12.50"
- UL and CSA recognition pending
- CE conformance pending

APPLICATIONS

- Clutch Brake Replacement
- Labeling Machines
- Packaging/Specialty Machinery
- Smart Conveyor Systems
- Semiconductor Wafer Polishing
- Constant Speed Applications

Pacific Scientific Model 6435 Oscillator/Microstepping Drive Package

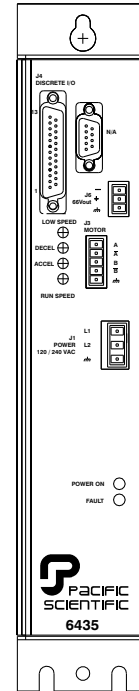

Photo not available
at time of printing.

PRODUCT DESCRIPTION

The Pacific Scientific 6435 is an economical, high performance microstepping drive with an integral oscillator. The package includes the highly popular 6410 drive and thus incorporates its many valuable features such as high resolution microstepping (200 to 51,200 steps per revolution) for smooth operation through resonance regions, mid-range Digital Electronic Damping, single supply operation, output current adjustment, and idle current reduction.

The 6435 contains a stable, wide range voltage controlled oscillator (VCO) which provides step pulses to the drive card. There are two frequency ranges, customer selectable by a jumper. The final runspeed is controlled by the following:

- Low/High speed select Input or
- on-board multi-turn potentiometers or
- external customer potentiometer or
- customer supplied -10 Vdc to +10 Vdc analog voltage

The relationship between the VCO pulse frequency and the motor shaft rpm is a function of the step size selected. Direction can be controlled by any of the following:

- Polarity of the Analog Input or
- Plug-On jumpers or
- Optically isolated discrete input

SPECIFICATIONS

Input Power

Voltage 120 - 240 Vac 60-50 Hz (switch selectable)
Line Current At full (300W) load
 240 Vac, 2.3 A RMS
 120 Vac, 3.5 A RMS

Output motor phase current

5 A rms max.
 5 A peak full step
 7.1 A peak microstepping
 Adjustable from 0.625 to 5 A rms in 0.625 amp increments

66 Vdc Output for 2nd axis (J6)

66 ±2 volts. Total power (internal + external) = 300W

RUN SPEED Control (Analog Input)

Analog Input Range ± 10 Vdc (Also controllable with internal or external pots)

Analog Input Impedance 20 KΩ (differential amp)

High Frequency Range

RUN SPEED Control 0 KHz to 500 KHz (8 KHz to 500 KHz with MIN SPEED Enabled)
 LOW SPEED Control 0 KHz to 370 KHz (8 KHz to 370 KHz with MIN SPEED Enabled)

Low Frequency Range

RUN SPEED Control 0 KHz to 250 KHz (4 KHz to 250 KHz with MIN SPEED Enabled)
 LOW SPEED Control 0 KHz to 180 KHz (4 KHz to 180 KHz with MIN SPEED Enabled)

RUN SPEED/LOW SPEED Stability Over Temp. /Range

±1% of full scale (typical)

ACCEL RAMP (exponential)

accel pot fully CW 0.4 sec (single time constant)
accel pot fully CCW 0.4 msec (single time constant)

DECEL RAMP (linear)

decel pot fully CW 1.4 sec
decel pot fully CCW 6.0 msec

MIN SPEED

4 KHz Maximum (high frequency range)
 2 KHz Maximum (low frequency range)
 Steps below this frequency are inhibited to insure no movement at end of decel ramp. This functionality can be disabled by inserting jumper E5.

Note: $Motor\ rpm = 0.3 * Freq.\ (Hz) / step\ size.$

For example: If frequency = 500,000 Hz and step size = 125, rpm = 1200.

Signal Input Requirements

Input	Min. Input Current - Opto ON	Max. Input Current	Max. Reverse Voltage
J4-19, J4-7 Low Speed	3.0 ma	4.5 ma	5 volts
J4-22, J4-10 Direction	3.0 ma	4.5 ma	5 volts
J4-23, J4-11 Enable	3.0 ma	4.5 ma	5 volts
J4-20, J4-8 Run	3.0 ma	4.5 ma	5 volts
J4-21, J4-9 Stop	3.0 ma	4.5 ma	5 volts

OSCILLATOR BOARD SETTINGS

Note: Factory default settings are in **bold**

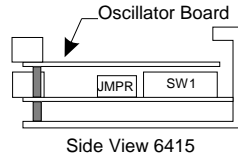

E2 - Frequency Range	
IN	LOW FREQUENCY
OUT	HIGH FREQUENCY

E4 - RUN/STOP Control	
IN	SEPARATE INPUTS
OUT	SINGLE INPUT

E5 - MIN SPEED Frequency	
IN	DISABLED
OUT	ENABLED

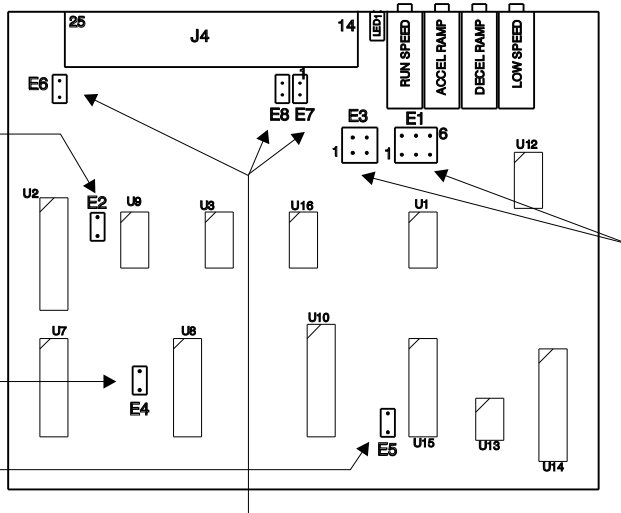

Control Source	E6	E7	E8	DIR Opto	Analog In	Rotation
DIR+/DIR-	OUT	OUT	OUT	Driven	-----	CCW
	OUT	OUT	OUT	Not Driven	-----	CW
Jumpers	IN	IN	OUT	Driven	-----	CCW
	OUT	OUT	OUT	Not Driven	-----	CW
Analog In	IN	OUT	IN	Driven	Negative	CCW
	IN	OUT	IN	Not Driven	Positive	CW

E1	E3 -	Velocity Control Mode
1-2 IN	1-2 IN	Internal RUN SPEED Potentiometer
3-4 IN	N/A	External Potentiometer
5-6 IN	1-2 IN	External Analog Input
1-2 IN	3-4 IN	External Analog Input scaled by internal RUN SPEED potentiometer

DRIVE BOARD SETTINGS

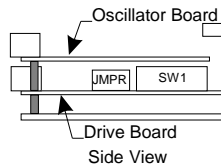

FACTORY DEFAULTS:
5.0 AMPS RMS
STEP SIZE 1/25
500 KHz MAX STEP RATE
IDLE CURRENT REDUCTION ENABLED (0.1 SEC)
DIGITAL ELECTRONIC DAMPING CONTROL ENABLED
DRIVER ENABLED UNLESS ENABLE OPTO DRIVEN

JUMPERS 1-2, 3-4, & 7-8 INSTALLED AT FACTORY DO NOT CHANGE

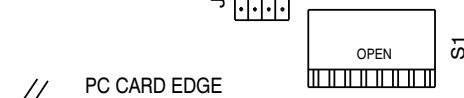

SW1 SIDE VIEW
FACTORY DEFAULT POSITIONS SHOWN

SW1 POSITION			STEP SIZE DEC JMPR IN
1	2	3	
CLOSED	CLOSED	CLOSED	FULL
CLOSED	CLOSED	OPEN	HALF
CLOSED	OPEN	CLOSED	1/5
CLOSED	OPEN	OPEN	1/10
OPEN	CLOSED	CLOSED	1/25
OPEN	CLOSED	OPEN	1/50
OPEN	OPEN	CLOSED	1/125
OPEN	OPEN	OPEN	1/250

SW1 POSITION			MOTOR CURRENT AMPS RMS
6	7	8	
CLOSED	CLOSED	CLOSED	5.0
CLOSED	CLOSED	OPEN	4.375
CLOSED	OPEN	CLOSED	3.750
CLOSED	OPEN	OPEN	3.125
OPEN	CLOSED	CLOSED	2.5
OPEN	CLOSED	OPEN	1.875
OPEN	OPEN	CLOSED	1.25
OPEN	OPEN	OPEN	0.625

SW1 POSITION 4	DIGITAL ELECTRONIC DAMPING
CLOSED	DISABLED
OPEN	ENABLED

IDLE-T JUMPER	SW1 POSITION 5	IDLE CURRENT REDUCTION
IN	CLOSED	DISABLED
IN	OPEN	0.1 SEC DELAY

I/O COMMAND AND MONITOR SIGNALS

RUN+/RUN-, STOP+/STOP-

Separate Latched Inputs (E4 jumper installed - Default)

With the E4 jumper installed, the RUN/STOP (Clutch brake) mode of the 6435 is controlled by two separate optically isolated inputs. When the RUN opto is driven momentarily, the RUN/STOP latch is placed in the RUN state and the oscillator frequency ramps to the selected speed at a rate controlled by the ACCEL potentiometer. When the STOP opto is driven momentarily, the RUN/STOP latch is placed in the STOP state and the oscillator frequency ramps to zero frequency at a rate controlled by the DECEL potentiometer.

The RUN/STOP latch is designed to be in the STOP state after applying power to the 6435 to insure that motion does not occur unintentionally.

Single Input (E4 jumper removed)

If the E4 jumper is removed, the RUN/STOP mode of the drive is controlled directly from the RUN input. When the RUN opto is driven, the oscillator frequency ramps to the selected speed at a rate controlled by the ACCEL potentiometer. When the RUN opto is off, the oscillator frequency ramps to zero frequency at a rate controlled by the DECEL potentiometer.

Enable

The drive is enabled unless the Enable opto is driven.

External Step Pulse

The step pulse output from the VCO is available on J4-12, J4-13, J4-24, and J4-25. This can be connected to up to four additional 6410 drives.

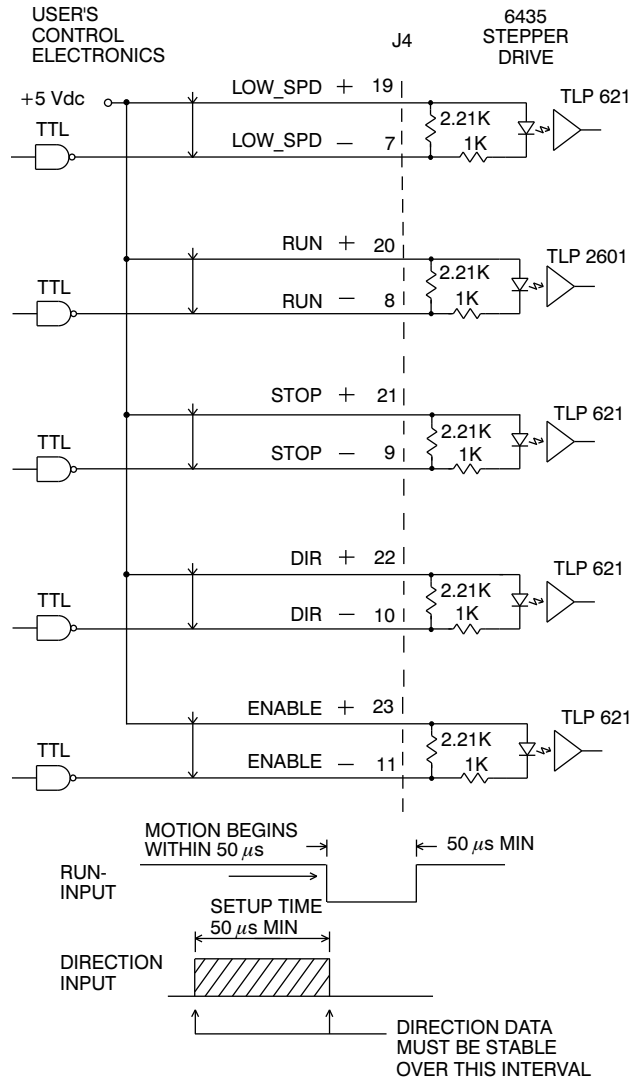

Figure 1 - 6435 Digital Interface Circuitry

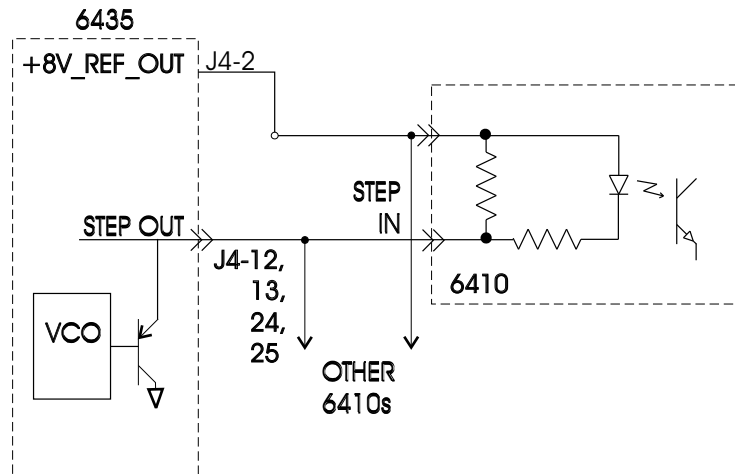

Figure 2 - External Step Pulse

LOW_SPD+/LOW_SPD-

This optically isolated input selects the source of the analog speed command. With the LOW_SPD opto on (J4-7 Low), the analog speed command is derived from the LOW SPEED potentiometer.

With the LOW_SPD opto off (J4-7 High), the analog speed command is derived from one of the following sources depending upon the E1 and E3 jumper configurations:

- Internal RUN SPEED potentiometer (E1 1-2 and E3 1-2 installed - Default)
- External potentiometer (E1 3-4 installed)
- External analog input (E1 5-6 and E3 1-2 installed)
- External analog input scaled (fine tuned) by internal RUN SPEED potentiometer (E1 1-2 and E3 3-4 installed)

The LOW_SPD input can be changed at any time. The speed (oscillator frequency) will not change instantly, but will ramp to the newly selected speed at a rate controlled by the ACCEL or DECEL potentiometers depending upon whether the speed (magnitude) is increasing or decreasing.

Figure 6 shows the velocity wave form in a typical application where the high speed is selected when the RUN input is pulsed and latched. Near the end of the motion profile, low speed is selected to insure a short and precise stopping distance when the STOP input is pulsed.

ADJUSTMENT POTENTIOMETERS

Figures 5 and 6 show the typical velocity (pulse frequency) profile in response to a separate RUN/STOP or with a single RUN/STOP and RUN/LOW commands.

Adjustments for RUN SPEED, LOW SPEED, ACCEL RAMP, and DECEL RAMP are made with 4 multi-turn potentiometers.

LOW SPEED is typically set lower than RUN SPEED to allow for accurate stopping. It can also be used as a second RUN SPEED. ACCEL RAMP is typically set to minimize time to reach RUN SPEED without allowing the motor to stall. The DECEL RAMP is linear and stable, allowing a more precise, repeatable stopping position.

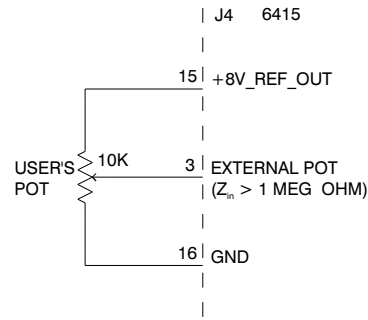

Figure 3 - External potentiometer

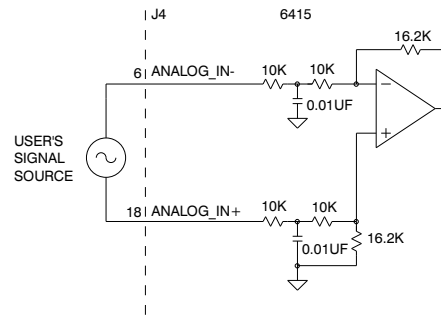

Figure 4 - Analog Input

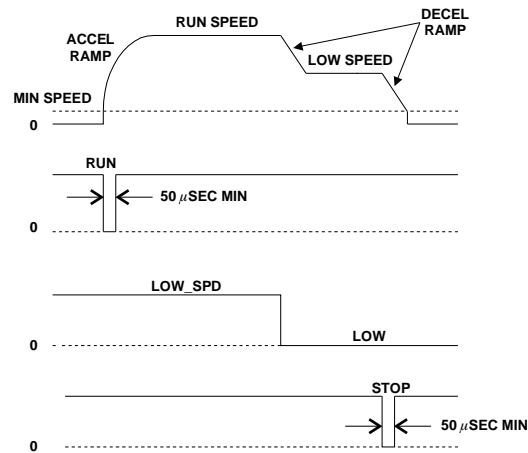

Figure 5 - Typical Velocity Profile with Separate RUN/STOP and RUN/LOW Command Signals

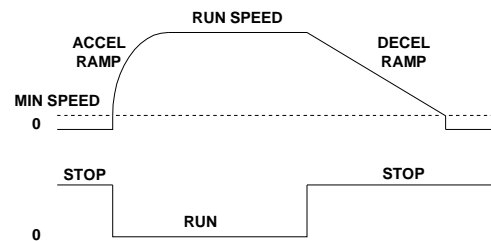

Figure 6 - Typical Velocity Profile with a Single RUN/STOP Command Signal

CONNECTION DIAGRAM

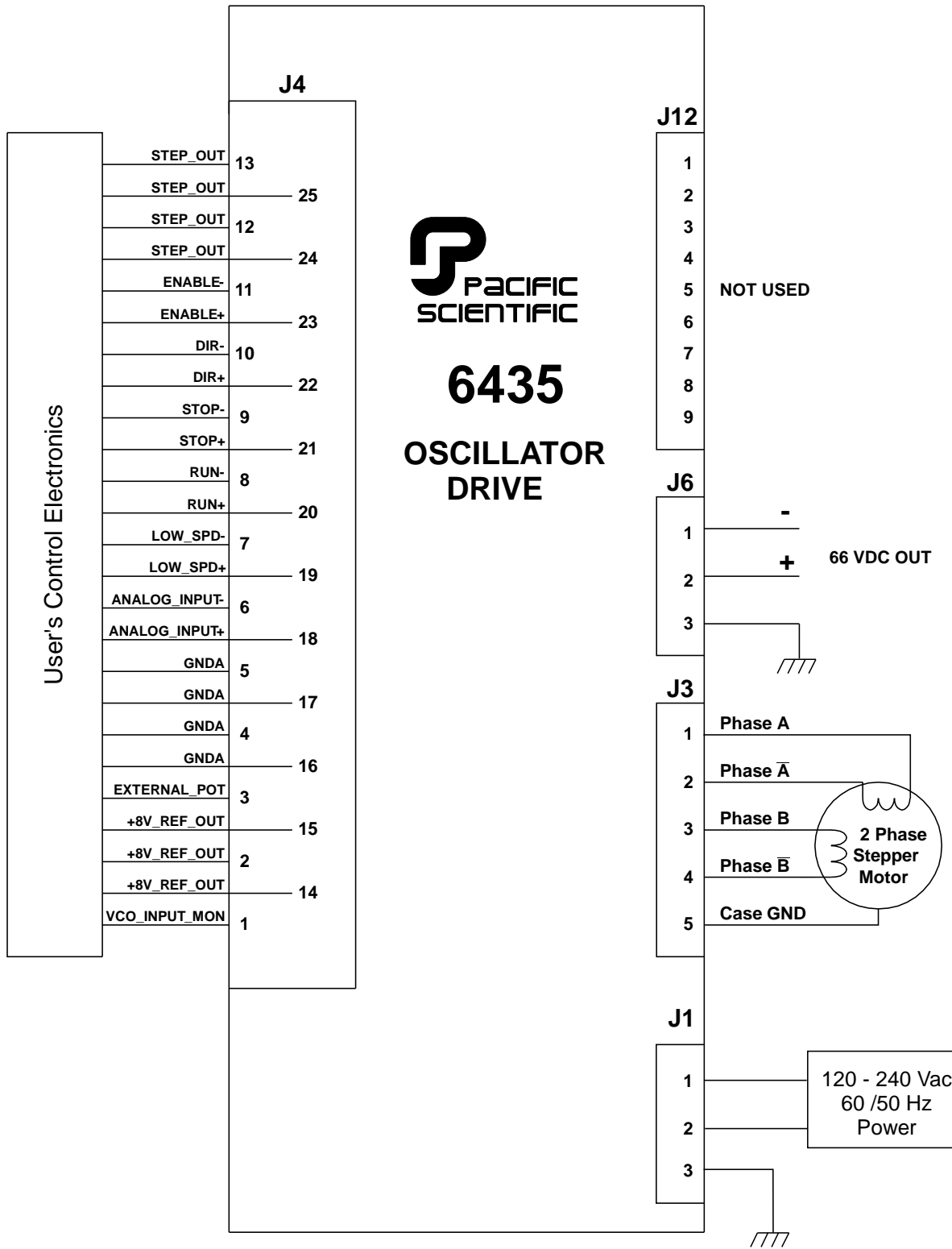

Figure 7 - 6435 Connection Diagram

MOUNTING DIAGRAM

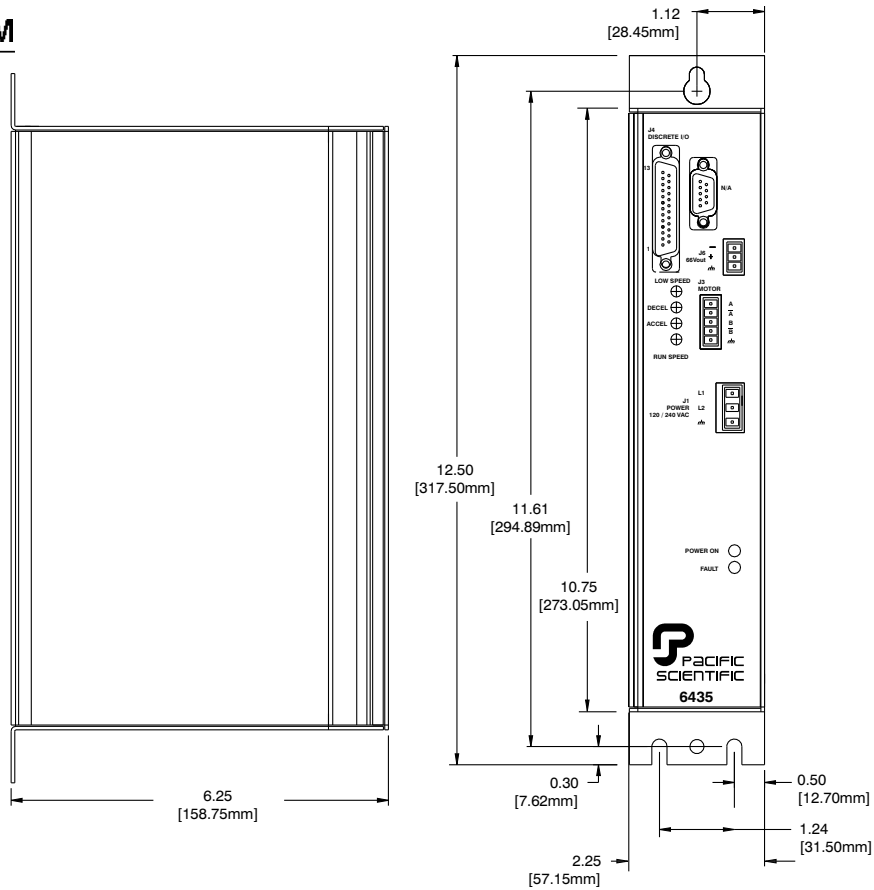
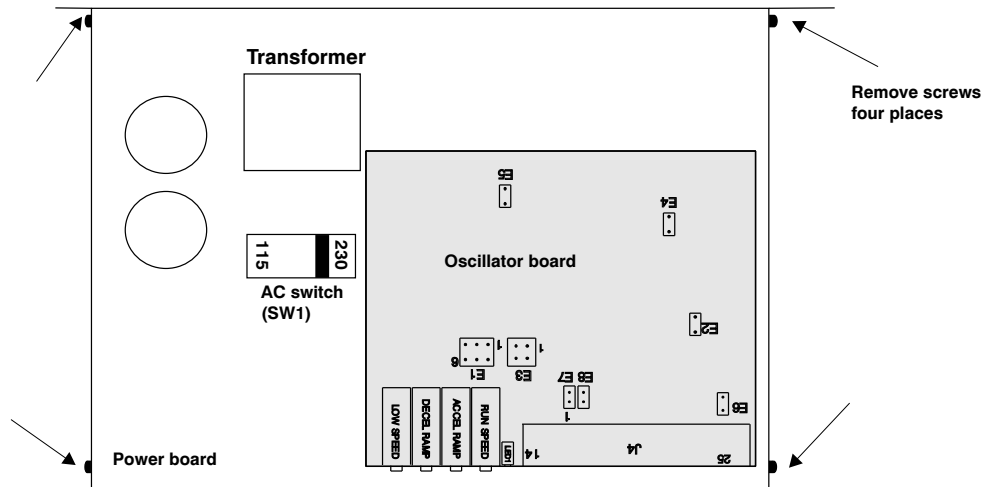

Figure 8 - 6435 Mounting Dimensions

AC SWITCH SETTINGS

The AC switch is preset at the factory in the 240 Vac position. The AC switch is easily accessible by opening the cover. **First, make certain the power connections have been removed.** Rest the unit on its side as shown. Remove the four screws. Select appropriate setting. Replace cover and mounting screws. Do **NOT** over tighten mounting screws. (5.0 in-lbs max)



66 VDC OUTPUT CONNECTOR J6

The 6435 package has an external 66 Vdc connector (J6) designed to power an additional drive. The total power available for both the internal and external drives is 66 Vdc @ 4.6 Amps or approximately 300 Watts. If the two drives are running simultaneously and require more than 4.6 Amps, the voltage will begin to cut back. The power supply has a low voltage protection circuit that will fault the drive if the dc supply dips below 55 Vdc.

A twisted pair plus ground cable utilizing 16, 18, or 20 gauge wire is recommended to connect the remote connector to the external drive. A 470 μ F 100 Vdc aluminum electrolytic capacitor, rated for 2A ripple current or greater, must be installed at the additional drive if the cable length is over 3 feet.

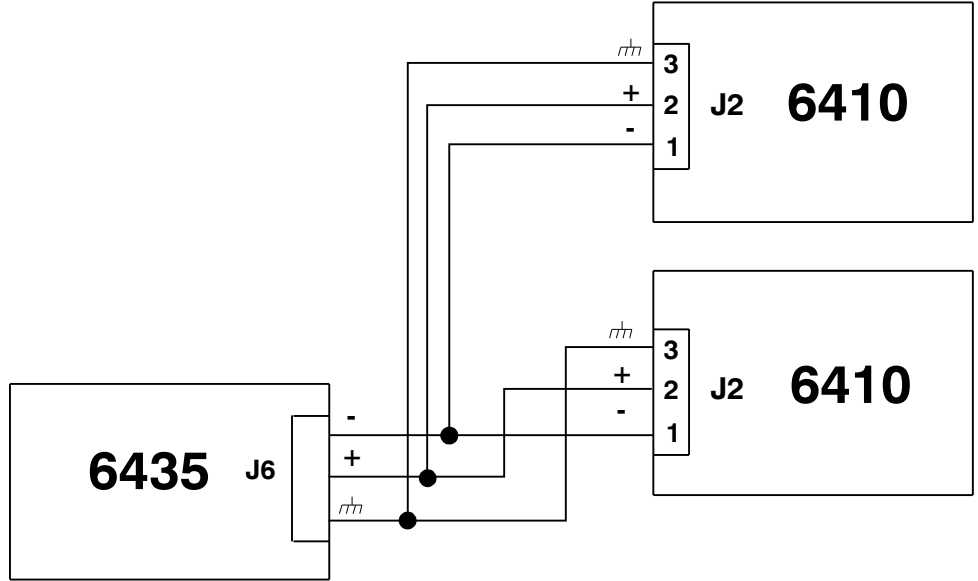

GETTING STARTED

Perform this initial power up with the motor shaft disconnected from the load. Improper wiring could result in undesired motion.

1. Connect the motor leads and power supply wires to the 6435 Oscillator Package connectors as shown.

Note: *J12 on the lower board is not used.*

2. Wire the control signals for the independent RUN, STOP and DIRECTION control into connector J4 as shown in Figure 1.
3. Pull the RUN signal Low (J4-8) and the motor will ramp up to speed. Pull the STOP signal low (J4-9) and the motor decelerates to a stop. When the DIRECTION signal is pulled low (J4-10) the motor will run in the CCW direction, looking at the motor shaft. If the desired rotation for a low signal is CW, swap the connections of the motor leads on pins J3-1 and J3-2.

Note: *Remove power from the drive before swapping the leads.*

4. If the motor emits a high frequency noise but the shaft is not rotating, stop the motor. Lower the RUN SPEED by turning the RUN SPEED potentiometer CCW. Increase the ACCEL RAMP by turning the ACCEL RAMP potentiometer CW.
5. After successfully establishing motion, the system can be powered down and connected to a load.

TROUBLESHOOTING

Power Board

SYMPTOM	POSSIBLE CAUSE	ACTION
Motor does not turn LEDs ON (green and/or red)	120/240 Vac switch in 240 position, input from 120 Vac	Turn power off, correct switch position.
	AC Input line low	Increase Input AC to spec.
	Dead short or overload across external 66 Vdc output connector (J6).	Remove short or reduce load.
	Over temperature	Check ambient temperature or internal fan malfunction/blockage.
	Bad load connection	Check load connection. Check J6 Vdc output with a voltmeter and ensure output voltage is 66V ±2%. 1. If output voltage > 70 Vdc and < 78 Vdc add a load and ensure Vdc is ≈ 66Vdc. 2. If output voltage > 78 Vdc, return 6430 to factory for service.
	Drive board fault	See table below.
Motor does not turn, LEDs OFF	Check AC input	Use proper input.
	240 Vac applied and switch in 120 Vac position.	Return to factory for service.
Motor runs for a while and stops, both LEDs come on	Over temperature.	Reduce load. Check for excessive ambient temperature. Check for internal fan malfunction/blockage.
Motor turns on and off on its own and red LED keeps flashing OR Motor stops after running once.	120 Vac applied and switch in 240 Vac position	Correct switch position.
	Over load.	Reduce load.
	AC input line low.	Check input AC line voltage for low line.
	Drive Board Fault.	See table below.
	Internal failure.	Return to factory for service.

Drive Board

SYMPTOM	CORRECTIVE ACTION
Motor produces no torque, Meter at J12-4 and J12-9 reads high.	Disconnect AC power then disconnect the motor cable and cycle the J1 power supply Off and On. If the meter reads low, check motor cable and motor for shorts across the windings or between the windings and the motor case.
Motor produces no torque, Meter at J12-4 and J12-9 reads low.	Verify that DIP Switch S1 position 6, 7, and 8 (current select) are set correctly. Re-check that the motor cable is wired correctly and properly plugged into the drive.
Motor produces torque but does not turn.	Make sure that the STEP input is switching and meets specified electrical and timing requirements.
Motor rotates in the wrong direction	Check polarity of the DIRECTION input. Also, check that the DIRECTION input satisfies the specified electrical and timing requirements. Reverse the A and \bar{A} motor phases.

Oscillator Board

SYMPTOM	CORRECTIVE ACTION
Motor produces no torque	<p>Disconnect the AC power. Disconnect motor cable and cycle the J1 power supply Off and On. Check the step output and VCO input monitor point. Also, check motor cable and motor for shorts across the windings or between the windings and the motor case.</p> <p>Verify that DIP Switch S1 position 6, 7, and 8 (current select) are set correctly.</p> <p>Re-check that the motor cable is wired correctly and properly plugged into the drive.</p>
Motor produces torque but does not turn.	<p>Make sure that the STEP output is switching.</p>
Motor rotates in the wrong direction.	<p>Check polarity of the DIRECTION input. Also, verify that the direction selection jumpers (E6, E7, E8) are set correctly.</p> <p>Reverse the A and \bar{A} motor phases.</p>
Motor does not reach expected position.	<p>Check that the step size setting of the drive and speed potentiometer are set correctly.</p> <p>Verify that the motor does not stall. If it does:</p> <ol style="list-style-type: none"> 1. Re-check sizing calculations. Be sure that the power supply voltage is high enough for the required torque vs. speed curve. 2. Use a finer step size to avoid low-speed resonance problems. 3. Enable Digital Electronic Damping (S1 position 4 OFF).
Drive is disabled.	<ol style="list-style-type: none"> 1. Turn the bus power off. 2. Disconnect the motor winding from the drive. 3. Turn the bus power back to on. Check that the +8V reference output (+8V_REF_OUT) is within specifications. 4. Remove any external connections to the enable input opto (ENABLE). 5. Reapply the power. If still disabled, Drive has an internal short.
Motor produces torque, but does not run.	<ol style="list-style-type: none"> 1. No Step pulses out - Check that there is a final speed command voltage at the VCO monitor test point (VCO_INPUT_MON) and the step pulses output (STEP_OUT) is switching. Also verify that E1 and E3 jumpers are set correctly. 2. Loss of phase current in one winding. Check phase current in both phases by placing an ammeter in series with each winding. If not present, check for open circuit in motor phase winding by measuring resistance. 3. One motor phase not wired correctly at stepping motor. Check stepping motor wiring. 4. Step pulses output (STEP_OUT) is too high. Lower step pulses output by adjusting Run Speed and Accel/Decel Potentiometers. Also check to make sure that the step size and frequency range jumper (E2) are set correctly.
Motor misses steps.	<p>Incorrect run speed or low speed. Adjust run speed potentiometer or low speed potentiometer.</p> <p>Incorrect accel ramp time or decel time. Adjust accel potentiometer or decel potentiometer.</p>

PERFORMANCE - 6400 SERIES CONTROLS

Motors will perform as shown without the winding temperature exceeding a rise of 90°C. When the motor is operated unmounted (without heat sink) in an ambient temperature of up to 40°C. The curves do not reflect systems resonance points, which will vary with motor coupling and systems parameters.

In addition to those shown below, Pacific Scientific offers a wide range of other motor windings to meet specific performance requirements.

Torque/Speed Curves - Recommended Motors for 5.0 A operation

(3" MOTOR-ONE ROTOR STACK)

E31NX-HTLNN-NS50
5.0A/65V PER PHASE

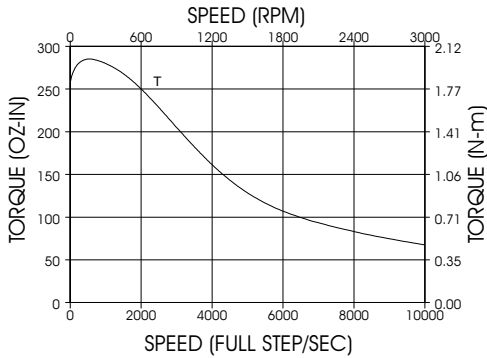

(3" MOTOR-TWO ROTOR STACK)

E32NX-HTLNN-NS50
E32NX-HPLNN-NS50
5.0A/65V PER PHASE

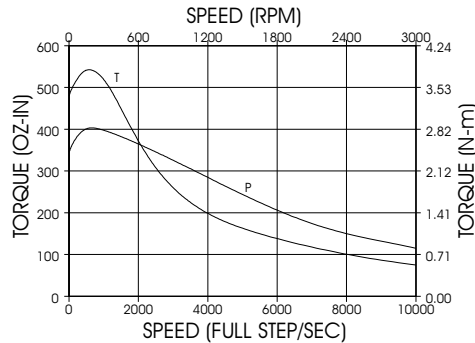

(3" MOTOR-THREE ROTOR STACKS)

E33NX-HTLNN-NS50
E33NX-HPLNN-NS50
5.0A/65V PER PHASE

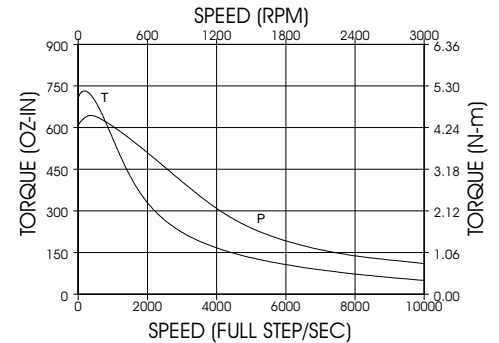

(3" MOTOR-FOUR ROTOR STACKS)

E34HX-HTLNN-NS50
E32HX-HPLNN-NS50
5.0A/65V PER PHASE

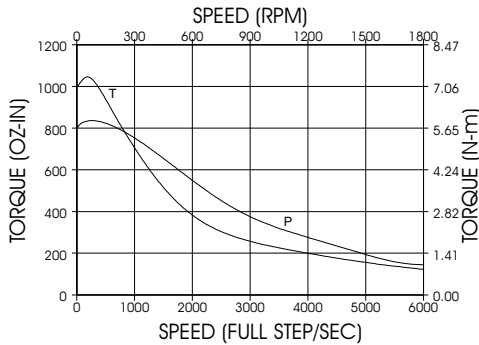

(4" MOTOR-ONE ROTOR STACK)

E41HX-HTLNN-NS50
5.0A/65V PER PHASE

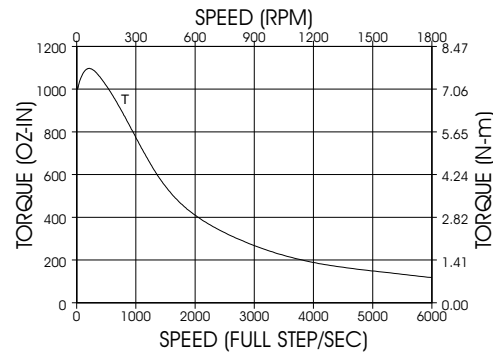

Torque/Speed Curves - Recommended Motors for 5.0 A operation

(3" MOTOR-TWO ROTOR STACK)

E32NX-LTLNN-NS50
E32NX-LPLNN-NS50
2.5A/65V PER PHASE

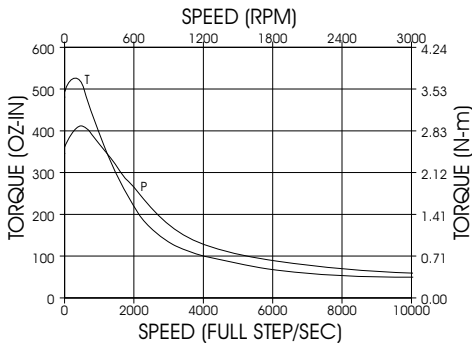

(3" MOTOR-ONE ROTOR STACK)

E31NX-LTLNN-NS50
E31NX-LPLNN-NS50
2.5A/65V PER PHASE

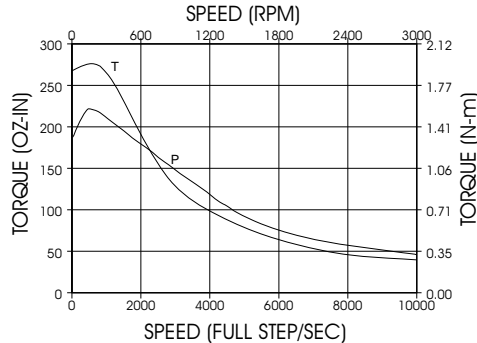

(2" MOTOR-TWO ROTOR STACKS)

E22NX-LTLNN-NS50
E22NX-LPLNN-NS50
2.5A/65V PER PHASE

